

# GTS SERIES

*Twin Spindles & Turrets CNC Turning Centers*

**GOODWAY MACHINE CORP.**

# GTS series Twin Turrets

## TWIN SPINDLES & TURRETS CNC TURNING CENTER

GTS series Twin Turrets

General Features

Accessories & Applications

Specifications

Designed for simultaneous turning of work pieces within one machines setup. The GTS series incorporates twin-opposing spindles and turrets with C-axis and live tooling capabilities. This configuration allows both turrets to work simultaneously with one turret at each spindle achieving ultimate efficiency.

### AVAILABLE

- ▶ Twin spindles, twin standard turrets.
- ▶ Twin spindles, one live tooling turret & one standard turret.
- ▶ Twin spindles, twin live tooling turrets.
- ▶ Twin Y-axis ( GTS-200 series only )
- ▶ C-axis or 1 deg. indexing spindles.



( GTS-150MMX series model shown. )

# General Features

GTS series Twin Turrets

General Features

Accessories & Applications

Specifications

## SPECIFICATION

The twin 12 stations turrets provides high speed indexing of 0.2 second from station to station. 1 step indexing further provides faster cycling times. Live tooling turret options enable the use of 6 live tool positions on each turret.

## MACHINING CAPABILITIES

Simultaneous turning on both spindles. The second spindle may be used to support longer work pieces during turning with the spindle synchronize RPM feature. The feature is also used when parting bar work. When the machine is incorporated with full C-axis and live tooling,

the GTS machines are able to perform the following: OD & face milling, OD & off-center face drilling.

## SPINDLES

Fanuc  $\alpha Pi$  series wide range spindle motors power both spindles and can be programmed for synchronized turning. The wide range constant output spindle motors provide full power cutting throughout most of the spindle speed range.  $Pi$  type motors also have faster acceleration and deceleration to cut down cycle times and torque rating are twice the output of standard  $\alpha i$  series motors.

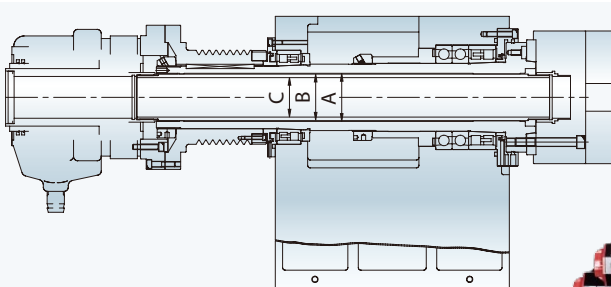
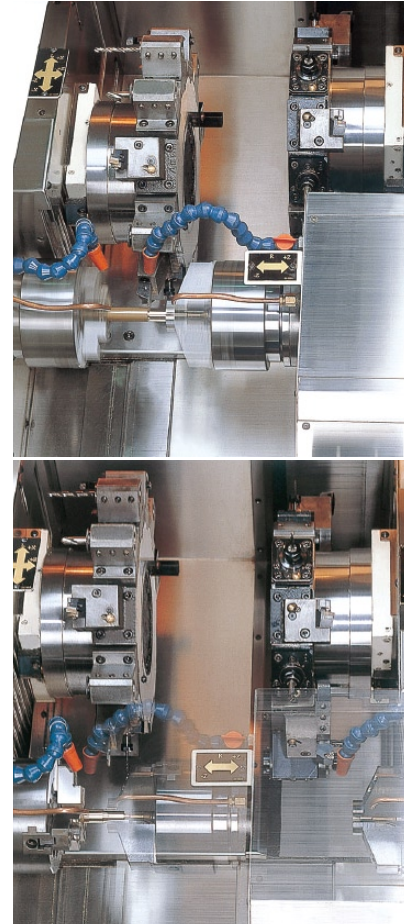

		A	B	C
GTS-150	Spindle 1/2	51	50	43
GTS-200	Spindle 1/2	66	65	52
GTS-260	Spindle 1/2	76	75	66

A : Spindle  
B : Draw tube OD  
C : Draw tube ID

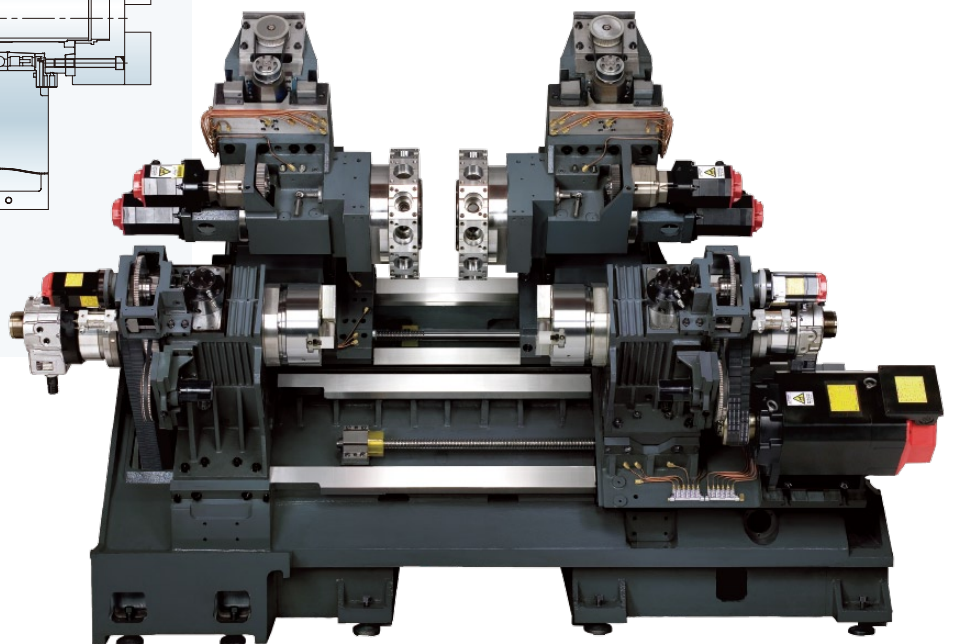

( Casting structure of GTS-260XY series model shown )

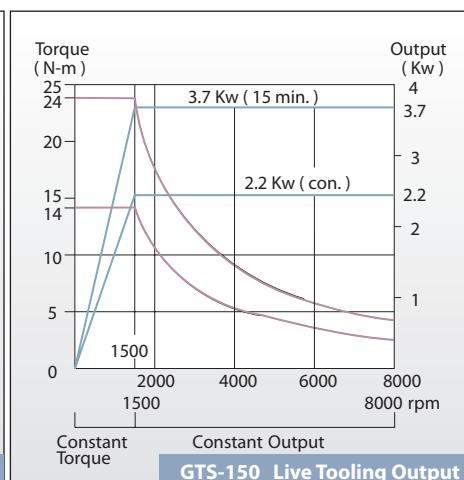
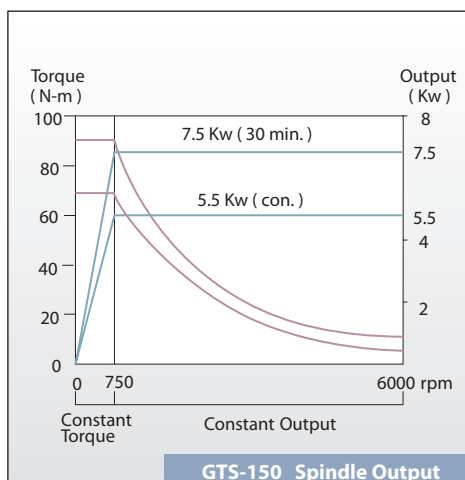
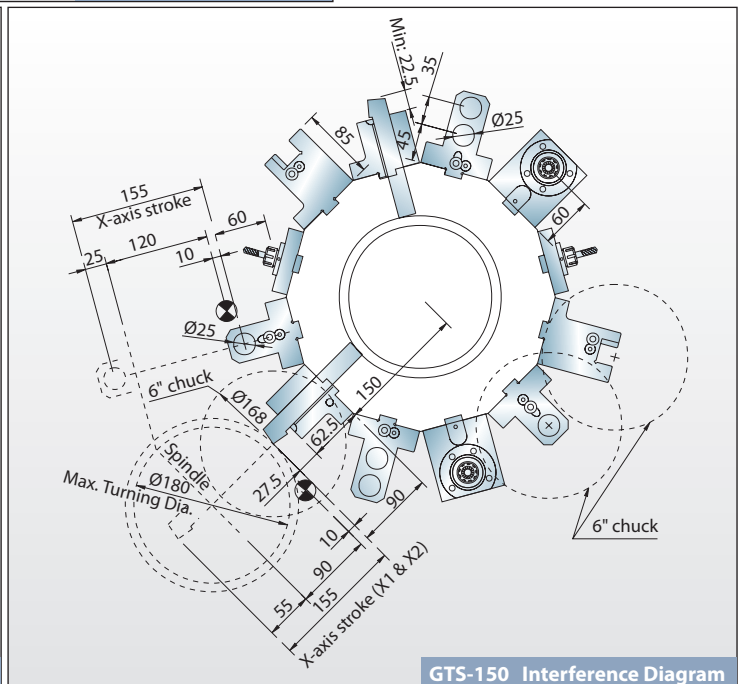
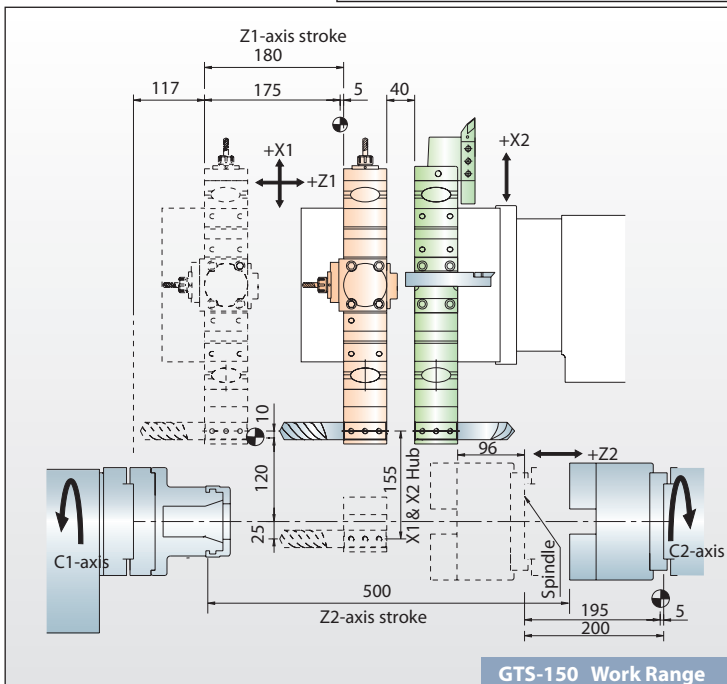
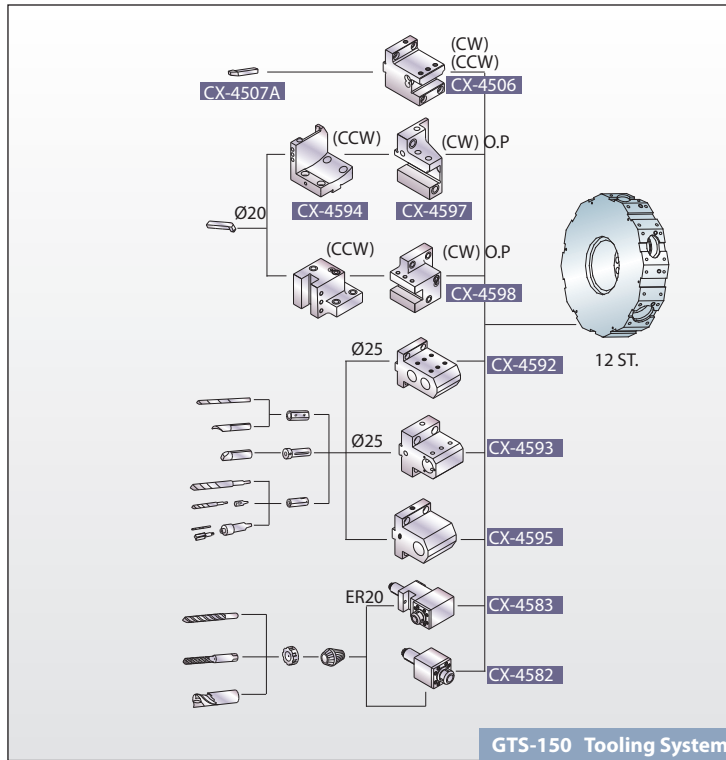

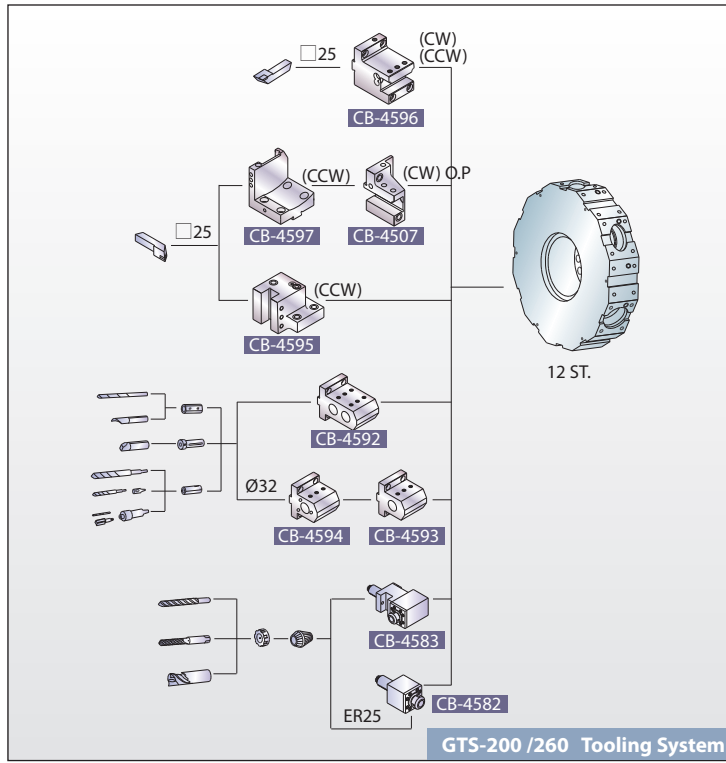

GTS-200 / 260 Tooling System

Unit : mm

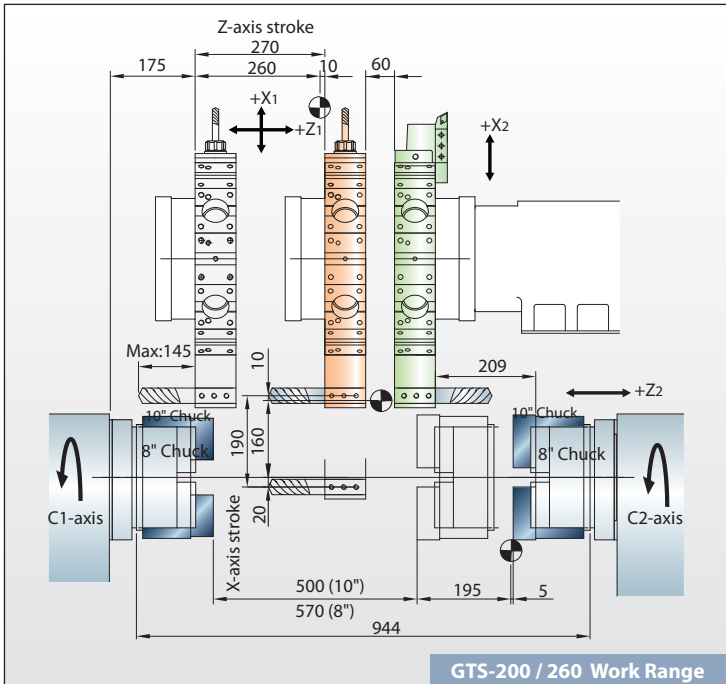

GTS-200 / 260 Work Range

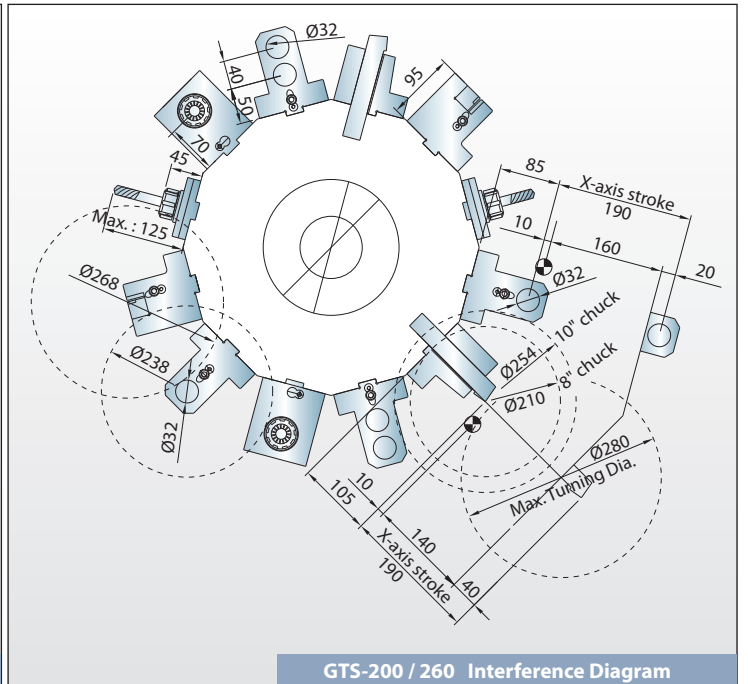

GTS-200 / 260 Interference Diagram

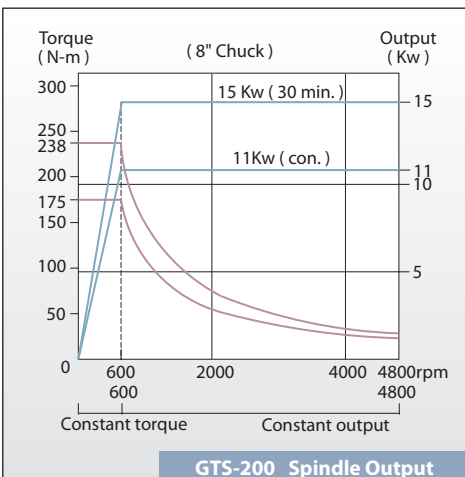

GTS-200 Spindle Output

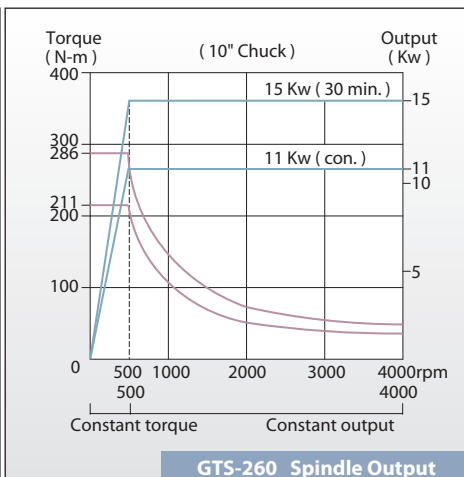

GTS-260 Spindle Output

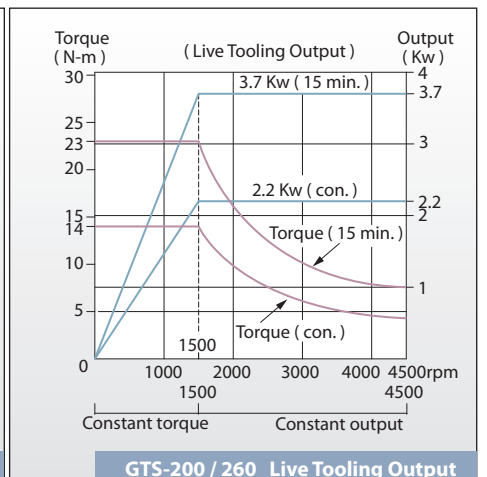

GTS-200 / 260 Live Tooling Output

# Accessories & Applications

GTS series Twin Turrets

General Features

Accessories & Applications

Specifications

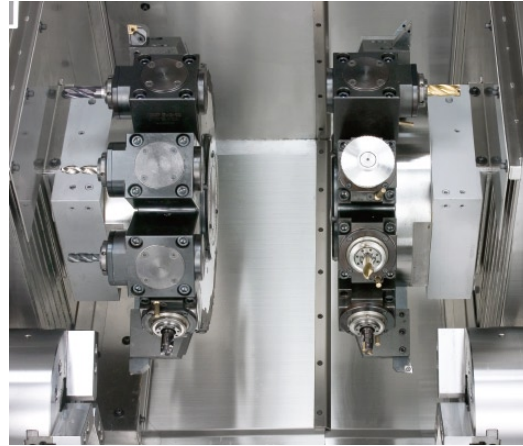

► GTS-200 series Live Tooling Turrets



► RENISHAW HPRa TOOLSETTER

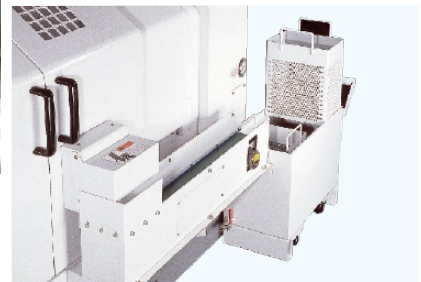

► PARTS CONVEYOR

## 1. Small Parts

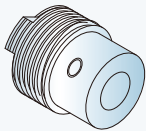

<b>H1 Cut Off</b> <ul style="list-style-type: none"> <li>• Synchronization cut off.</li> </ul>	<b>H2 Workpiece Support</b> <ul style="list-style-type: none"> <li>• Spindle stop.</li> <li>• H2 advance with chuck open.</li> <li>• Chuck close.</li> <li>• Synchronization cut off.</li> <li>• H2 retract after cut off.</li> </ul>	<b>H1 Load Bar</b> <ul style="list-style-type: none"> <li>• Spindle stop.</li> <li>• Collect chuck open.</li> <li>• Load Bar.</li> <li>• Collect chuck close.</li> <li>• Spindle run.</li> <li>• O. D. and Thread machining.</li> </ul>	<b>H2 Turn / Mill Operation</b> <ul style="list-style-type: none"> <li>• Turning / drilling.</li> <li>• Milling.</li> <li>• Eject to parts catcher.</li> </ul>

## 2. Long Parts

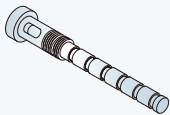

<b>H1 Drilling</b> <ul style="list-style-type: none"> <li>• C-axis brake.</li> <li>• Drilling.</li> <li>• Cut off workpiece.</li> </ul>	<b>H2 Workpiece Support</b> <ul style="list-style-type: none"> <li>• Chuck hold workpiece.</li> </ul>	<b>H1 Load Bar</b> <ul style="list-style-type: none"> <li>• Collect chuck open.</li> <li>• Load Bar.</li> <li>• Collect chuck close.</li> <li>• O. D. and Thread machining.</li> </ul>	<b>H2 Turn / Mill Operation</b> <ul style="list-style-type: none"> <li>• End face and O. D. machining.</li> <li>• Finished.</li> </ul>

## 3. Casting / Forge Parts

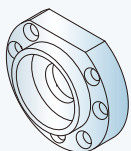

<b>H1 Workpiece Support</b> <ul style="list-style-type: none"> <li>• Workpiece finished in H1.</li> <li>• Spindle stop / chuck open.</li> <li>• Load new workpiece / chuck close.</li> </ul>	<b>H2 Workpiece Support</b> <ul style="list-style-type: none"> <li>• Spindle stop.</li> <li>• H2 advance with chuck open.</li> <li>• H2 retract after cut off.</li> </ul>	<b>H1 Turn operation</b> <ul style="list-style-type: none"> <li>• Synchronization.</li> <li>• O. D. machining.</li> <li>• Bore machining.</li> </ul>	<b>H2 Turn / Drill Operation</b> <ul style="list-style-type: none"> <li>• END face and O. D. machining.</li> <li>• Drilling</li> <li>• Finished.</li> </ul>

# Specifications

GTS series Twin Turrets

General Features

Accessories & Applications

Specifications

## Specifications

MODEL	GTS-150	GTS-200 / 260
Max. turning diameter	Ø 180 mm	Ø 280 mm
Max. turning length	180 mm	200 mm
Max. swing over cover	180 mm	280 mm
Bar capacity	Ø 42 mm	Ø 51 / 65 mm
Spindle speed range	60 ~ 6,000 rpm	48 ~ 4,800 rpm / 40 ~ 4,000 rpm
Spindle drive system	Direct-coupled 1:1 pulleys	Direct-coupled 3:1 pulleys
Spindle motor ( Max. rating )	5.5 / 7.5 Kw AC	11 / 15 Kw AC
Hole through Spindle	Ø 51 mm	Ø 66 / 76 mm
Spindle bearing diameter	Ø 80 mm	Ø 100 / 120 mm
Spindle nose	A2-5 ( 6" )	A2-6 ( 8" ) / A2-8 ( 10" )
Head 2 slide travel	500 mm	700 mm
Turrets	12 Station x 2	12 Station x 2
Turret index time	0.2 sec. / adjacent	
Live tooling stations*	6 Stations	
Live tooling drive motor*	2.2 / 3.7 Kw AC	
Live tooling RPM	Axial 4,000 rpm, radial 4,000 rpm	
Max. X1/ X2 travel	155 mm	190 mm
Max. Z1 travel	180 mm	270 mm
Max. Z2 travel	500 mm	740 mm
X1 / X2 rapid traverse rate	15 m/min.	20 m/min.
Z1 / Z2 rapid traverse rate	36 m/min.	24 m/min.
X-axis servo motors	1.6 Kw AC Absolute	3 Kw AC Absolute
Z-axis servo motors	1.6 Kw AC Absolute	3 Kw AC Absolute
Slide way type (All axes)	linear way	Box way
Tool size square	□ 20 mm ( 3/4" )	□ 25 mm ( 1" )
Tool size round	Ø 25 mm ( Ø1" )	Ø 32 mm
Live tooling shaft diameter*	13 mm / ER 20	16 mm / ER 25
Part catcher capacity* D x L	Ø 42 x 130 mm	Ø 65 x 160 mm
CNC control	FANUC 18i-TB	
Voltage	AC 200 / 220 +10% to - 15% 3 Phase	
Hydraulic tank capacity	50 L	
Coolant tank capacity	140 L	150 L
Coolant Pumps	1/2 HP grundfos pump x 2 ( 3.8 Bars/ 55 PSI )	
Machine dimensions L x W x H	2,450 x 1,700 x 1,830 mm	3,030 x 1,805 x 1,970 mm
Approx. machine weight	6,000 Kg	7,800 Kg

\*Optional

### Optional Twin Y-axis ( GTS-200 series only )

Max. turning diameter	280 mm
Max. X-axis travel	220 mm
Max. Y-axis travel	120 mm = ± 60
X / Y axes rapids	20 / 20 m/min.
Slide way type	Box way
Feed rates	1 ~ 4,800 mm/min.
X-axis servo motor	4 Kw AC Absolute
Y-axis servo motor	1.6 Kw AC Absolute
X-axis ball screw Ø / pitch	Ø 36 mm / pitch 8
Y-axis ball screw Ø / pitch	Ø 32 mm / pitch 6
X / Y axes thrust ( Con. )	1,763 Kg / 855 Kg

## Machine Layout

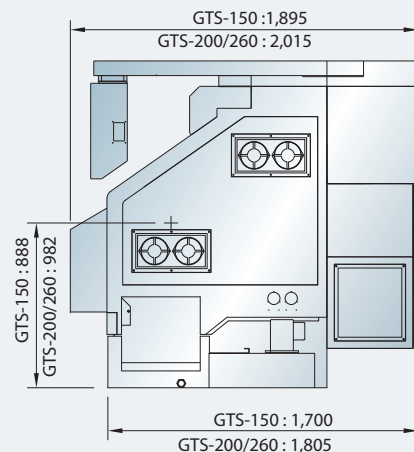
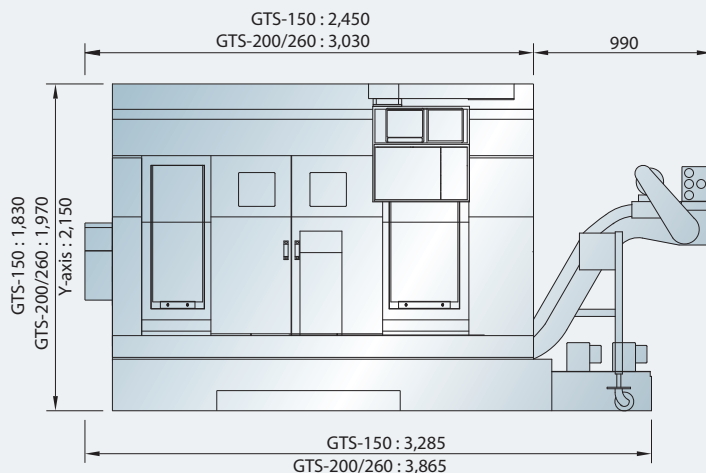

Unit : mm



---

## **GOODWAY MACHINE CORP.**

### **Headquarters :**

No.13, 5Th Road,  
Taichung Industrial Park,  
Taichung City, 407, Taiwan, R.O.C.  
TEL : + 886-4-2359-1226  
Website : [www.goodwaycnc.com](http://www.goodwaycnc.com)  
E-mail : [goodway@goodwaycnc.com](mailto:goodway@goodwaycnc.com)

### **GOODWAY (SUZHOU) MACHINE CORP.**

No.589, Chengyang Road,  
Xiang Cheng Economic Development District  
Suzhou City, Jiangsu, China  
TEL : + 86-512-6576-3699  
TEL : + 86-512-6576-7299  
Website : [www.goodwaycnc.com.cn](http://www.goodwaycnc.com.cn)  
E-mail : [goodway.suzhou@goodwaycnc.com.tw](mailto:goodway.suzhou@goodwaycnc.com.tw)

### **Central Taiwan Science Park Branch :**

No. 38, Keyuan Road,  
Central Taiwan Science Park.Taichung,  
Taichung City, 407, Taiwan, R.O.C.  
TEL : + 886-4-2463-6000  
TEL : + 886-4-2463-9600